

Fiberglass Corro-Blast Centrifugal



PCP Poly Composite Products, LLC

51 North Street / P.O. Box 400
LeRoy, NY 14482
Phone: (585) 768-7633 Fax: (585) 768-7634
Website: www.PolyCP.com
Email: sales@PolyCP.com

Corro-Blast Centrifugal Features

The Polymil Products Corro-Blast Centrifugal Exhauster is designed for continuous operation in corrosive industrial or commercial applications. The motor is completely isolated from the airstream in a fiberglass compartment. Contaminated air is discharged at a high rate of speed away from the building. Ideal for waste water treatment facilities, pulp and paper mills, laboratory hood exhaust and chemical process plants.

Features

- **Sizes:** 10" and 12", direct drive, 15" through 36", belt driven.
- **Material:** Fiberglass, Hetron 99P ® polyester resin, Class 1 flame spread of 25. Standard color is gray.
- **Wheel:** Backward inclined design of the fiberglass wheel provides quiet operation and a non-overloading horsepower quality.
- **Motor Cover:** Fiberglass motor cover is easily removable for maintenance.
- **Motor Base:** Constructed of fiberglass and adjustable for belt tensioning.
- **Drain:** Provided.
- **Disconnect:** Mounted in the drive compartment and factory pre-wired.
- **Hardware:** 304 stainless steel.



Accessories

- **Spark Resistant Construction:** Includes carbon veil, graphite impregnation and static grounding lugs to make unit electrically conductive, limiting the possibility of a static charge.
- **Special Resins:** A variety of special resins are available to suit a specific corrosive application.
- **Base:** Curb mounting available.
- **Damper:** Fiberglass construction. Automatic back-draft or motor operated damper. Designed to mount on a curb damper tray.
- **Birdscreen:** 1/2" black polyethylene mesh prevents drawing of foreign matter into the wheel assembly.
- **Disconnect:** NEMA 3R, mounted on exterior of unit and factory pre-wired.
- **Hardware:** 316 stainless steel available.

Corro-Blast Centrifugal Dimensions

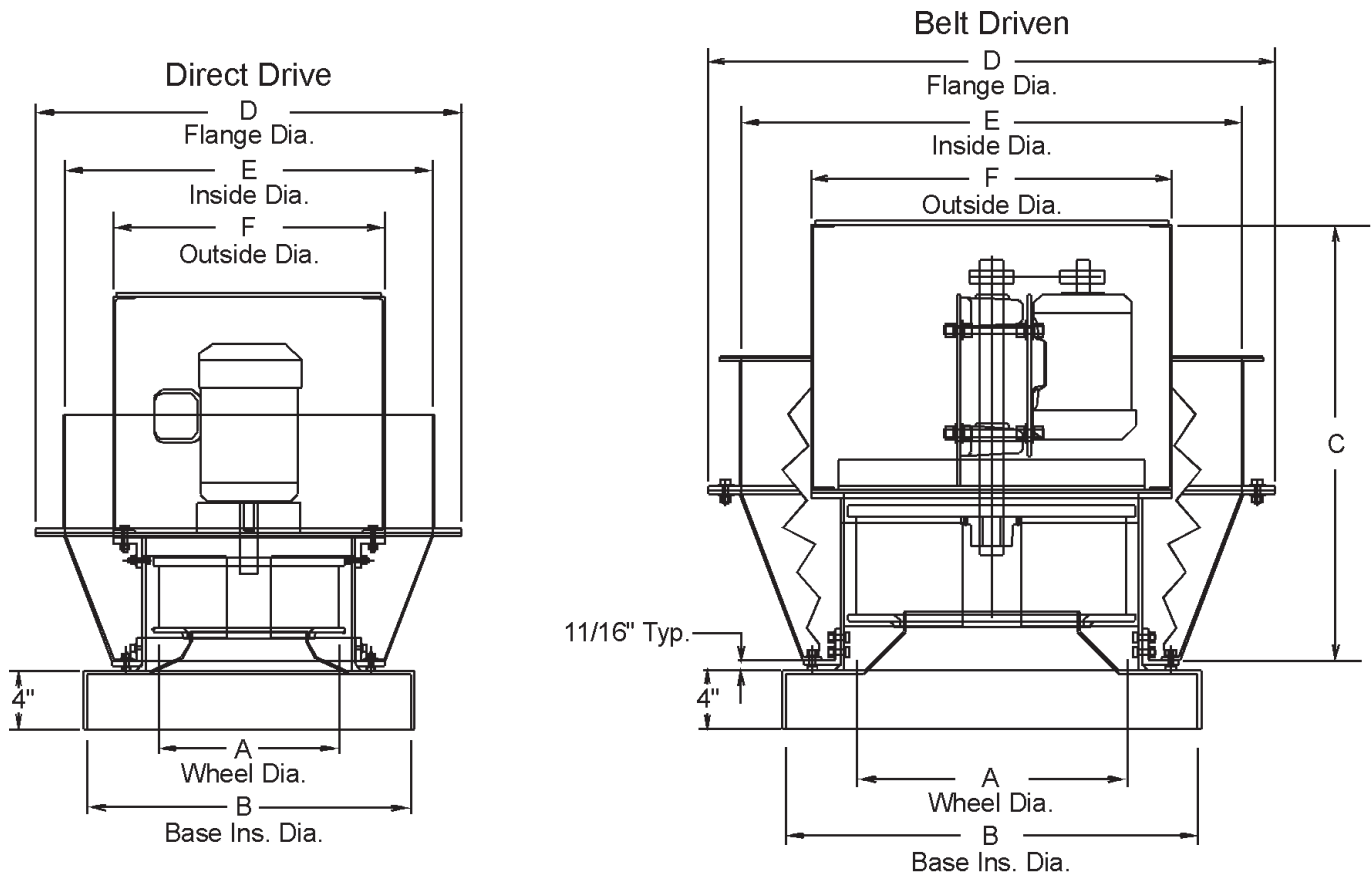

Size	A	B	C	D	E	F
10"*	10-5/8	20	22-1/2	26-3/16	23-3/16	16-1/2
12"*	12-1/4	22	25-9/16	29	25	18-1/2
15"	15-5/16	25	29-1/16	32-3/4	28-3/4	22
18"	18-3/8	28	30-3/8	38-1/2	34	24-1/2
24"	24-1/2	34	37-7/8	49-1/2	45	31-1/2
30"	30-5/8	42	44-3/8	61	56	38
36"	36-3/4	52	47-5/8	69-13/16	65-5/16	45

* Sizes 10" and 12" are direct drive units

Specifications

Furnish _____ each, size _____, Model CB as manufactured by Polymil Products, Inc.

Housing shall be constructed of Hetron 99P® polyester resin with a Class 1 flamespread of 25 or less incorporating UV inhibitor and synthetic surfacing veil.

Fan wheel shall be constructed of fiberglass using Hetron 992 FR® vinyl ester resin and attached to shaft by a taperlock bushing. The bushing shall be protected by a fiberglass cover. Fan shaft shall be of 304 stainless steel with a neoprene shaft seal.

The fan shall have a capacity of _____ CFM at _____ inch(es) static pressure standard air and equipped with a _____ HP, _____ RPM, motor. It shall be NEMA design B, heavy duty, industrial continuous duty, totally enclosed fan cooled and suitable for _____ volt, _____ phase, _____ cycle operation. The bearings

shall be self-aligning block type. Unit shall be equipped with an adjustable v-belt drive selected with a 1.5 service factor. Motor base plate shall be fiberglass and adjustable for belt tensioning. Motor and drive shall be protected by a fiberglass motor cover.

All hardware shall be 304SS.

A disconnect switch shall be provided mounted in the motor compartment and factory pre-wired to the motor.

Available accessories include: carbon impregnation with static grounding, fiberglass curb mounting, fiberglass dampers shall be (auto backdraft, 115v motor actuated with motor mounted in or out of airstream), 1/2" polyethylene mesh birdscreen, NEMA 3R mounted on exterior of unit, 316SS hardware.



PCP Poly Composite Products, LLC

51 North Street / P.O. Box 400
LeRoy, NY 14482
Phone: (585) 768-7633 Fax: (585) 768-7634
Website: www.PolyCP.com
Email: sales@PolyCP.com